



Bobcat®

Trencher Attachment



NOT A STEP



One Tough Animal™

Specifications

Trencher	MX112	LT112	LT113	LT213	LT313 (3')	LT313 (4')	LT414 (4')	LT414 (5')	LT405
Side Shift	N/A	Manual side-shift	Manual side-shift	Manual side-shift**	Manual side-shift**	Manual side-shift**	Hydraulic side-shift	Hydraulic side-shift	Hydraulic side-shift
Chain	1.654 in. (42 mm) chain Double Standard ABF	1.654 in. (42 mm) chain Double Standard ABF	1.654 in. (42 mm) chain Double Standard ABF	1.654 in. (42 mm) chain Double Standard ABF	2 in. (51 mm) chain Double Standard ABF	2 in. (51 mm) chain Double Standard ABF	2 in. (51 mm) chain Double Standard ABF	2 in. (51 mm) chain Double Standard ABF	2 in. (51 mm) chain Double Standard ABF
Auger	12 in. (305 mm) diameter single removable auger	12 in. (305 mm) diameter single removable auger	12 in. (305 mm) diameter single removable auger	12 in. (305 mm) diameter single removable auger	14 in. (356 mm) diameter single removable auger	14 in. (356 mm) diameter single removable auger	14.25 in. (362 mm) to 12 in. (305 mm) step auger	14.25 in. (362 mm) to 12 in. (305 mm) step auger	12 in. (305 mm) diameter dual augers
Chain Tensioning	Grease cylinder chain tightener	Grease cylinder chain tightener	Grease cylinder chain tightener	Grease cylinder chain tightener	Grease cylinder chain tightener	Grease cylinder chain tightener	Grease cylinder chain tightener	Grease cylinder chain tightener	Grease cylinder chain tightener
Chain Options	Chain options available	Chain options available	Chain options available	Chain options available	Chain options available	Chain options available	Chain options available	Chain options available	—
Operating weight*	570 lb. (259 kg)	615 lb. (279 kg)	640 lb. (290 kg)	725 lb. (329 kg)	955 lb. (433 kg)	980 lb. (444 kg)	1188 lb. (539 kg)	1225 lb. (556 kg)	1520 lb. (689 kg)
Trenching Widths Available	4-8 in. (102-203 mm)	4-8 in. (102-203 mm)	4-8 in. (102-203 mm)	4-8 in. (102-203 mm)	6-12 in. (152-305 mm)	6-12 in. (152-305 mm)	6-12 in. (152-305 mm)	6-8 in. (152-203 mm)	6-12 in. (152-305 mm)
Flow Range	13-20 gpm (49-76 L/min.)	9-15 gpm (30-57 L/min.)	9-15 gpm (30-57 L/min.)	11-18 gpm (42-68 L/min.)	15-22 gpm (57-83 L/min.)	15-22 gpm (57-83 L/min.)	26-40 gpm (98-151 L/min.)	26-40 gpm (98-151 L/min.)	26-40 gpm (98-151 L/min.)
Maximum Operating Pressure	3000 psi (20864 kPa)	3000 psi (20864 kPa)	3000 psi (20864 kPa)	3300 psi (22750 kPa)	3300 psi (22750 kPa)	3300 psi (22750 kPa)	3300 psi (22750 kPa)	3300 psi (22750 kPa)	3300 psi (22750 kPa)
A. Overall Length	68.2 in. (1758 mm)	60.7 in. (1542 mm)	74.0 in. (1880 mm)	74.0 in. (1880 mm)	79.5 in. (2019 mm)	89.5 in. (2273 mm)	90.0 in. (2286 mm)	104.0 in. (2642 mm)	105 in. (2667 mm)
B. Standard Boom Length	39.4 in. (1000 mm)	39.4 in. (1000 mm)	52.5 in. (1334 mm)	52.5 in. (1334 mm)	55.5 in. (1410 mm)	65.5 in. (1664 mm)	65.0 in. (1651 mm)	79.0 in. (2011 mm)	63 in. (1600 mm)
C. Dig Depth @ 60 degrees	24 in. (610 mm)	24 in. (610 mm)	36 in. (915 mm)	36 in. (915 mm)	36 in. (915 mm)	48 in. (1219 mm)	50.0 in. (1270 mm)	62.0 in. (1575 mm)	48-60 in. (1218-1524 mm)
D. Frame Width	30.6 in. (777 mm)	36 in. (915 mm)	36 in. (915 mm)	56.0 in. (1422 mm)	56.0 in. (1422 mm)	56.0 in. (1422 mm)	56.25 in. (1429 mm)	56.25 in. (1429 mm)	65 in. (1651 mm)
E. Side-Shift Travel	N/A	16.1 in. (409 mm)	16.1 in. (409 mm)	**23.1 in. (587 mm)	**23.1 in. (587 mm)	**23.1 in. (587 mm)	21.8 in. (554 mm)	21.8 in. (554 mm)	26 in. (660 mm)
F. Auger Clearance	13.8-15.8 in. (351-401 mm)	13.8-15.8 in. (351-401 mm)	13.8-15.8 in. (351-401 mm)	13.8-15.8 in. (351-401 mm)	24-27 in. (607-686 mm)	24-27 in. (607-686 mm)	23.4 in. (594 mm) -26.4 in. (671 mm)	23.4 in. (594 mm) -26.4 in. (671 mm)	19 in. (483 mm)

*Without teeth

**Optional hydraulic side-shift available. Hydraulic side-shift to right.

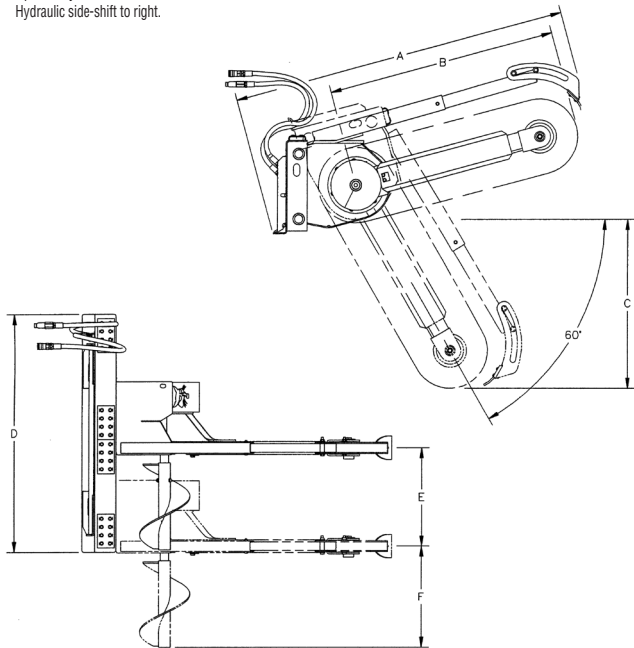

Trenchers that really dig their work!

Tackle tough trenching jobs with Bobcat trencher attachments designed and built specifically for Bobcat loaders. That means reliable, cost-effective production as well as Bobcat warranty, parts and service support.

With 2- and 3-foot dig depths, the LT112, LT113 and LT213 are ideal for light-to-medium trenching jobs. The LT313, with its 3- or 4-foot dig depth, can easily handle medium-to-high production trenching. The LT112, LT113, LT213 and LT313 models feature manual side-shift—with an optional hydraulic side-shift available on the LT213 and LT313. The LT414 and LT405, with 4- or 5-foot dig depths, are high-production trenchers for use on Bobcat loaders with high-flow capability.

NOTE - Where applicable, dimensions are in accordance with Society of Automotive Engineers (SAE) and ISO standards. Specifications and design are subject to change without notice. Pictures of Bobcat units may show other than standard equipment. All dimensions are given for loader equipped with standard tires. All dimensions are shown in inches. Respective metric dimensions are enclosed by parentheses. Bobcat Company complies with the requirements of ISO 9001 as registered with BSI.

The Bobcat Attachments Advantage: Bobcat attachments are engineered and manufactured to fit Bobcat loaders for optimum job performance, dependability and durability.

Bobcat Trencher Attachments fit these carrier models:

Mini Track Loaders:
MT52
MT55

Skid-Steer Loaders:

463
S70
S100
S130
S150
S160
S175
S175H
S185
S185H
S205
S205H
S220
S220H
S250
S250H
S300
S300H
S330
S330H
S630

Compact Track Loaders:

T110
T140
T180
T180H
T190
T190H
T250
T250H
T300
T300H
T320
T320H
T630
T650

All-Wheel Steer Loaders:

A300
A300H

Utility Work Machine:

5600
5610

Compact Excavators:

331
331E
334
335
337
341
430
435
E32
E35

VersaHandler TTC:

V417



Printed on 10% recycled paper

Visit bobcat.com/anyjob for more information

B-1661 (7/09)



Bobcat®

Bobcat Company • P.O. Box 6000 • West Fargo, ND 58078

Printed in U.S.A.

Kn-5M-709-#18001-F

Check out similar attachments:
Backhoe
Digger